



# MINING INDUSTRY PRODUCT CATALOG

Complete pumping  
solutions for your  
washing system.



# WHO ARE WE?

Trivikram Flowtech (TFT) is the ultimate destination, where we provide fluid solutions for a wide range of industries. Our areas of expertise include application engineering, R&D, selection of pumps and much more. Accepting all of that, we offer an extensive range of positive displacement and

centrifugal pumps favouring the commercial markets. Our products are of premium quality, reliable and robust for usage in industrial, domestic and agricultural markets. Our pumps are synonymous to providing leading performance and high efficiency.

## Our front-line pumping services include:

- Pump selection and field study
- Commissioning and installation
- After-sales service
- Technical seminars
- Rental services



**SYNONYMOUS TO PROVIDING LEADING PERFORMANCE AND HIGH EFFICIENCY.**

# WHY SHOULD YOU CHOOSE US?

We are a team of self made experts with an exceptional 25 years experience.

experience + expertise, we are confident enough to back you up.

We believe that the right product & it's supporting partners, combined together help the business grow. With TFT's positive approach & decades of

We are always upgrading & responding to the needs of the business. We redefine your business in every aspect.

Here is our multi-pronged approach which has helped us serve our customers effectively:



### PERSONALISED METHODOLOGY:

Our solutions for you are tailor made. Your business is one of a kind, so are our services for you. A lot of objective understanding is what goes in here.



### EXCEPTIONAL QUALITY:

We add real value to your business. Our team evaluate your needs according to your business activities at every stage & present you the end result.



### COMPLETE TRANSPARENCY:

Our communication with you is the real deal. We make sure you're part of every process to know how we're progressing and also be well informed.



### 24/7 CUSTOMER SUPPORT:

Our utmost priority is customer satisfaction and providing timely assistance is central to our philosophy. Reach out to us anytime.



# WASHING SYSTEM



Washing systems ensure that the end product maintains superior quality and adheres to the required standard for the end product's utilisation.

Pumps and cyclone classifiers play a predominant role in this process.

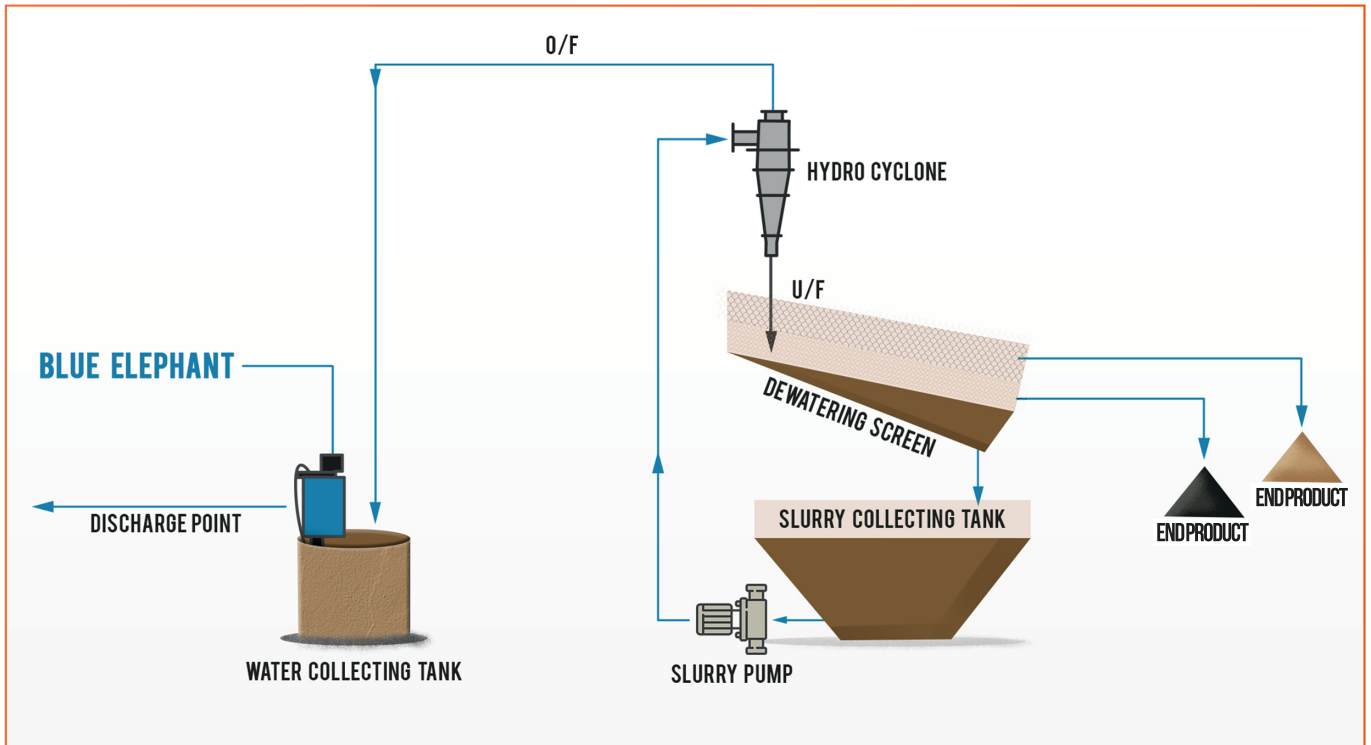

At TFT, we have been working extensively in Mining and Sandwashing Industries by serving our customers an array of different products that are highly efficient and have versatile functionality. We have studied, researched and developed several products that will invariably help in the production of End Product. We make sure that your business runs smoothly.



# SLURRY PUMP



Slurry pump is considered as the **HEART OF YOUR WASHING PLANT.**

Used for feeding cyclones at the required flow and specific head, the slurry pump is available in a wide range of sizes.

AVAILABLE  
SIZES:

2x1.5

3x2

4x3

6x4

8x6

10x8

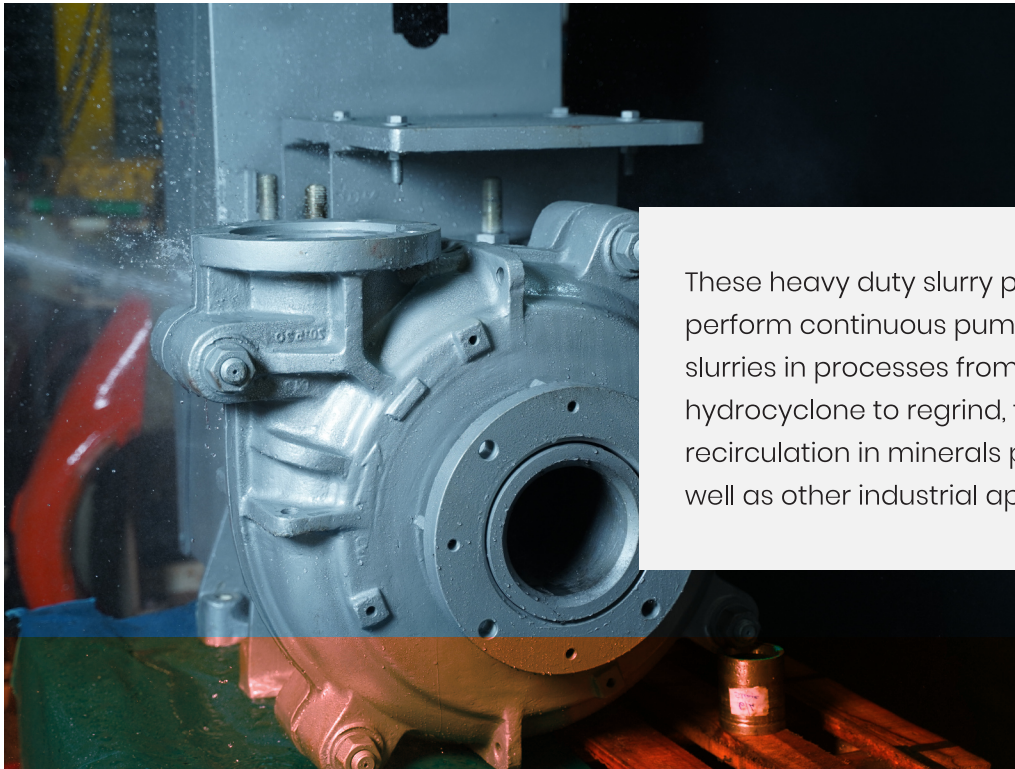

These heavy duty slurry pumps are designed to perform continuous pumping of highly abrasive slurries in processes from feeding the hydrocyclone to regrind, flotation and recirculation in minerals processing plants as well as other industrial applications.

The manufacturing techniques adopted in these pumps help us put together a product with proven performance and superior life. We have designed these pumps with simple strip down and reassembly process so that we minimise the downtime in processing industries. Also, with expeller seal arrangement, these pumps prevent leakage of slurry.

Keeping in mind the abrasion that these pumps undergo, we have made sure that they are heavy duty in nature. The wetted parts of TFT Slurry pumps are made with high abrasion and corrosion resistant, high chromium alloys with a hardness of 550 – 600 BHN. which ensures better life because of their high wear and tear resistance property. We know that performance of the slurry pump directly affects the feed of the cyclone which in turn results in the quality of the sand product, therefore we make sure these pumps work to the best of your expectation.





## SPECIFICATIONS:

- **Delivery Size** : DN 50 to 400 mm
- **Capacity** : Up to 2000m<sup>3</sup>/hr
- **Head** : Up to 88 m
- **Temperature** : Up to 110° C
- **Wetted parts** in Hi-chrome (Hardness of 550 – 600 BHN)
- **Other Parts** : Standard MoC (MS & CI)

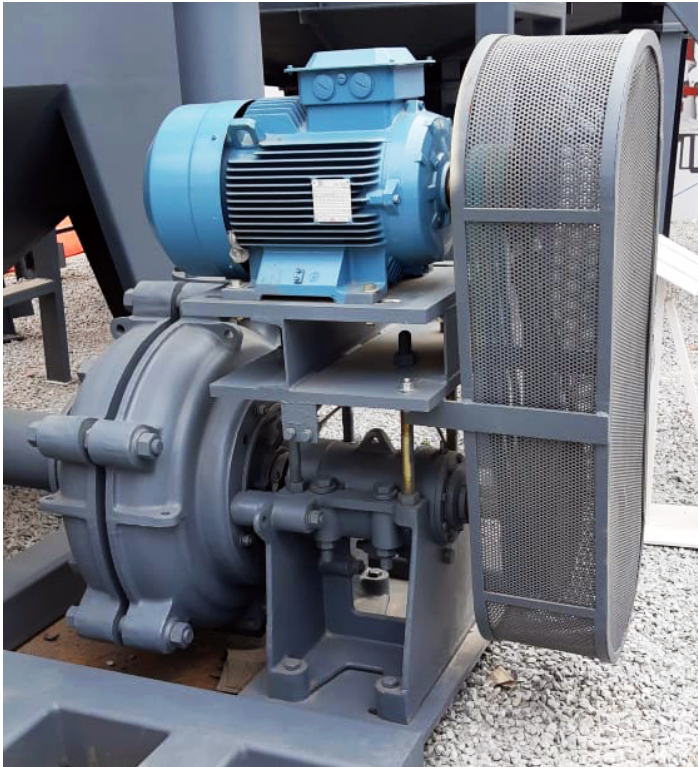

## DESIGN FEATURES



Twin Casing



Heavy Duty



Performance Driven



Abrasion Resistant



Easy Maintenance

We offer rental pumps to temporarily replace your pumps that are under service, so that your business can keep running without any hurdles. This will drastically minimise your plant's downtime and keeps your business running.



# SUBMERSIBLE SLURRY PUMP



Also known as Blue Elephant, this series is a submersible three-phase cast iron high flow heavy-duty slurry pump. The cast iron body with high-chromium semi-open impeller enables it to withstand demanding conditions found in construction, aggregate and mining applications.



In Mining and washing industry, Blue elephant is mainly used in pumping out and displacing the silt slurry wastage (rejected wastage in Hydrocyclone and Bucket classifier).

These pumps are designed with high-chrome impellers that withstand the most demanding of conditions. They perform exceptionally well in de-silting process and are very much helpful in improving the environmental aspects.

## SPECIFICATIONS:

- **Model** : Blue Elephant
- **Max. Head** : 32M
- **Max. Flowrate**: 130 CU.M/HR
- **Type** : Submersible
- **Wetted parts** in Hi-chrome
- **Other Parts** : Standard MoC (MS & CI)



Suitable for handling sewage and silt slurry liquid.



## DESIGN FEATURES



The body of the motor & pump is made of rigid cast iron for long-lasting durability.



Greatly increased maximum submersion depth due to mechanical seal resistant to high pressure.



Semi-open impeller made of high chrome alloy matched with wear plate (ductile iron) achieves super durability.



# HYDOCYCLONE



Another versatile yet efficient product that is used in the washing industry is Hydrocyclone.

Ranging from 250mm through to 600mm, these products are used in filtering sand particles of required size from the finer dust particles.

AVAILABLE SIZES:

250MM

325MM

400MM

500MM

600MM

Significance of the hydrocyclone can be understood when we find that the performance of the hydrocyclone directly impacts the quality of the end product output.

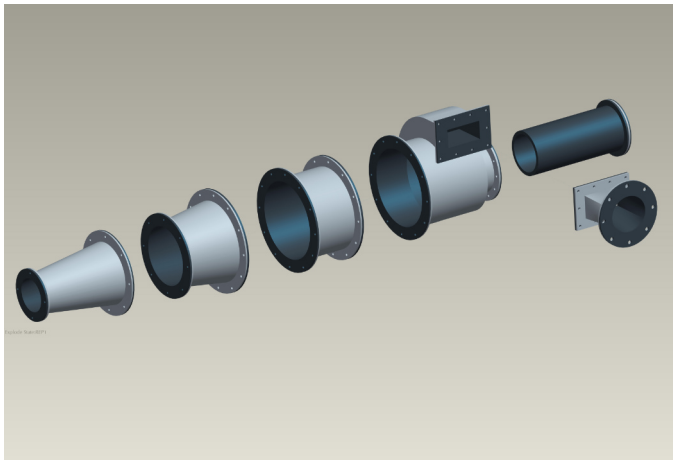

## WHY TFT CYCLONES?

Whether the application is sand-washing or classifying high-end minerals, our process engineer have long experience in successfully applying this product into stand-alone applications and integrated systems.

With our in-house developed simulations, we can reliably predict outcomes of different scenarios to evaluate new or existing installations.

Using the application predictions and the 'been there, done that' experience, our team develops the best approach to any process requirements.



Our hydrocyclones are lined with special Polyurethane coating that has a high shore hardness of 93A, where most of the conventional hydrocyclones offer upto 70D.

### KEY ADVANTAGES



Bouncing character of the Polyurethane lining



3 Times more wear resistant than Tungsten Carbide



High Impact Strength



High Abrasion Resistance



High Cut Resistance

# AUTO-PRIMING DEWATERING PUMP



## SPECIFICATIONS:

- **Model :** Tiger Series
- **Delivery Size :** DN 100 mm to 300 mm
- **Capacity :** Up to 550m<sup>3</sup>/hr
- **Head :** Up to 50 m
- **Temperature :** Up to 100° C
- **Max Solid Size :** 60 mm

# SELF-PRIMING PUMP



## SPECIFICATIONS:

- **Delivery Size :** Upto 150 mm
- **Capacity :** Up to 125 m<sup>3</sup>/hr
- **Head :** Up to 25 m
- **Max Solid Size :** 23 mm





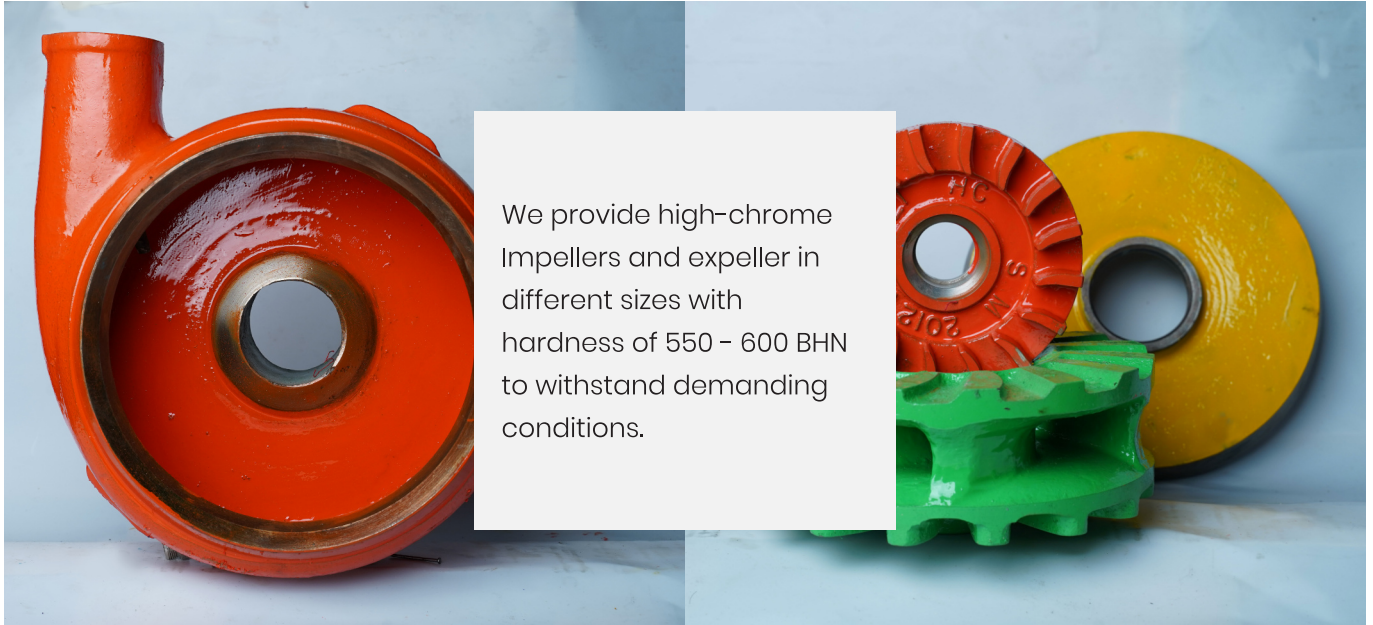

We provide high-chrome Impellers and expeller in different sizes with hardness of 550 - 600 BHN to withstand demanding conditions.

## PU SCREENING PANELS:

TFT PU mesh provides high strength, durability and also can withstand heavy loads. It can effectively absorb impact and reduce the noise thereby improving the working environment of the concern.



## SLURRY & MUD WATER SUCTION AND DISCHARGE HOSE

### Construction

- Core** Black colour, Synthetic and natural rubber blend resistant to abrasion
- Reinforcement** High Tensile Synthetic Textile Cord with 2 cross anti static wire
- Cover** Black colour, Synthetic rubber resistant to ozone, weather and abrasion
- Application** For suction and discharge of slurry, mud and waste water



Item Code	Dash Size	ID		OD		WP		BP		W
		inch	mm	inch	mm	psi	bar	psi	bar	kg/m
PH 647-32	-32	2	51.0	2.64	67.0	150	10	450	30	2.80
PH 647-48	-48	3	76.0	3.66	93.0	150	10	450	30	4.70
PH 647-64	-64	4	102.0	4.80	122.0	150	10	450	30	5.40
PH 647-80	-80	5	127.0	5.79	147.0	150	10	450	30	6.20
PH 647-96	-96	6	152.0	6.85	174.0	150	10	450	30	12.60
PH 647-128	-128	8	203.0	9.33	237.0	150	10	450	30	19.70



Temperature Range: Continuous: -30°C to +70°C

# OUR CUSTOMER SUPPORT



## TFT 24/7 CARE

To insure good health of your pumps, it's important to keep a check regularly.

That's why, TFT Care, a 24x7 customer support line is made accessible to every client out there to ensure 100% efficiency of both your pump and business.



### Our engineers will be with you round the clock for services like:

- ✓ Regular inspection, analysis of conditions and maintenance of your pumps at the site to avoid unexpected breakdowns.
- ✓ Overhauling, testing of critical components & undertaking repair works to improve the overall performance level of your pumps.
- ✓ Providing readily available critical spare parts to replace failed or worn out parts.



We care for our customers. We always make sure your pump is healthy and runs your business efficiently.





# OUR PRESTIGIOUS CLIENTS



---

# Accessible, Where ever You Are.

TFT Pumps Now Exporting Worldwide.

## GET IN TOUCH WITH US:

### HEAD OFFICE:

📍 21, Indira Nagar, Gopalsamy Colony, KNG  
Pudhur Pirivu, Thadagam road,  
Coimbatore, TN – 641025

☎ +91-9943049621 | +91 95974 38001

@ sales@tftpumps.com  
digital@tftpumps.com

### BRANCH OFFICE:

📍 #44/1/17, Singh Layout, Arekere 80 ft Road,  
BG Road, Bengaluru, Karnataka – 76

☎ +91-9943049621 | +91-95852 17711 | +91-95852 21194

@ sales@tftpumps.com  
karnataka@tftpumps.com

### BRANCH OFFICE:

📍 191, Metro Pillar, Muttom, Aluva,  
Ernakulam, Kerala – 683106

☎ +91-9943049621 | +91-98942 47166

@ sales@tftpumps.com  
kerala@tftpumps.com

---